



COSMOS in Germany

Martin Claussen

*Max Planck Institute for Meteorology
Meteorological Institute, University of Hamburg*



- λ What did we say in Lüneburg (2 slides from last year)
and
- λ what progress did we make?
- λ A few remarks on COSMOS (where to go)
and
- λ what shall we tackle next? (2 discussion points)

COSMOS: discussion

- **COSMOS** = COmmunity earth System MOdelS

Do we aim at one model system with different model components?

Or do we include different model systems?

- What about a coordination structure?
- What about funding?

COSMOS: discussion

- There is a strong need for **COSMOS** to be competitive with other international initiatives.
- There is an advantage of **COSMOS** being an open access initiative.
- **COSMOS** is interesting!
(if it is not restricted to an “COSMOS-n user meeting”.)
- There is a need for marketing
(enlarging the community, search for potential funding partners)

- New **networkplan** (almost final)

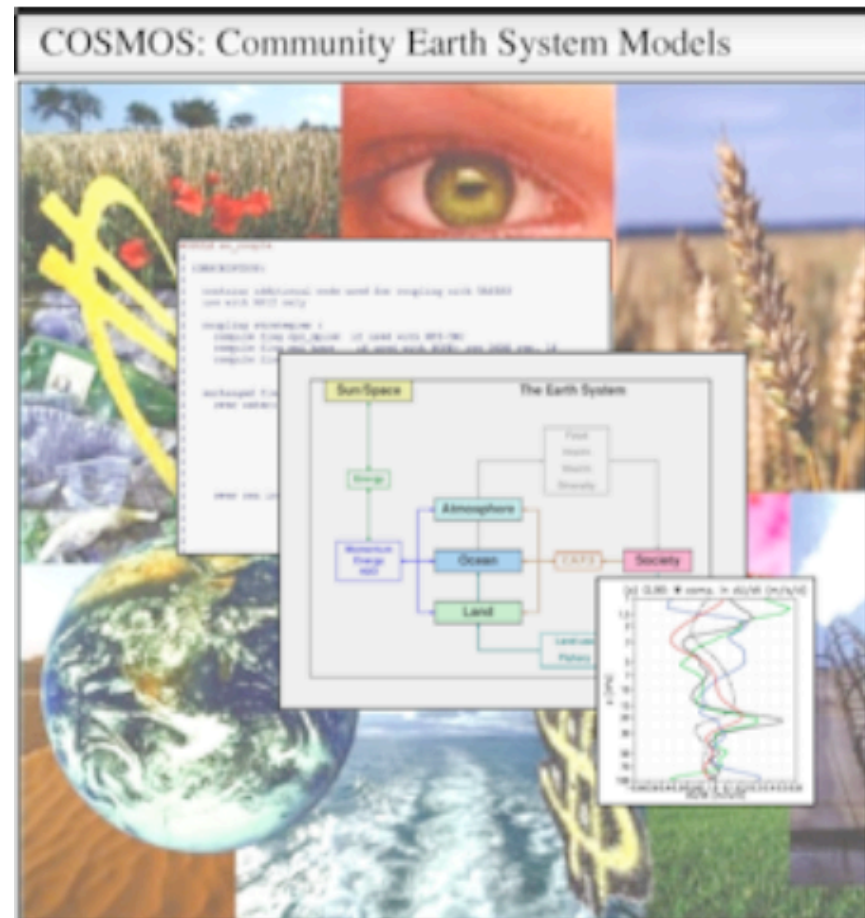

- New **networkplan** (almost final)
- New organisation structure with new COSMOS Board

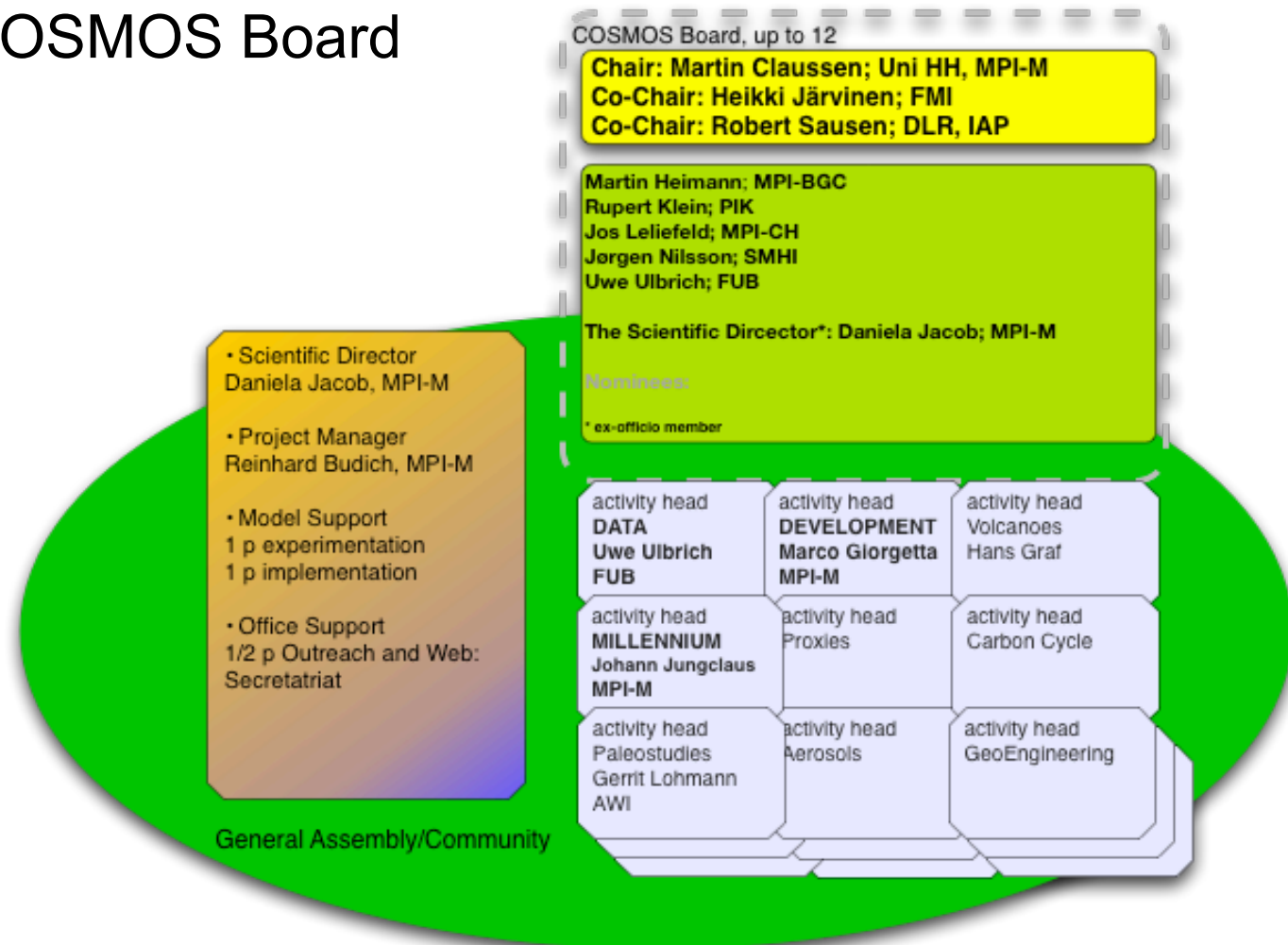



Current status



- New **networkplan** (almost final)
- New organisation structure with new COSMOS Board
- **New Memorandum of Understanding**





Current status



- New **networkplan** (almost final)
- New organisation structure with new COSMOS Board
- New Memorandum of Understanding
- **Terms of references of the COSMOS Board (almost final)**



x.x.x = 1.0.0 \diamond IPCC model

cosmos1.0.0.

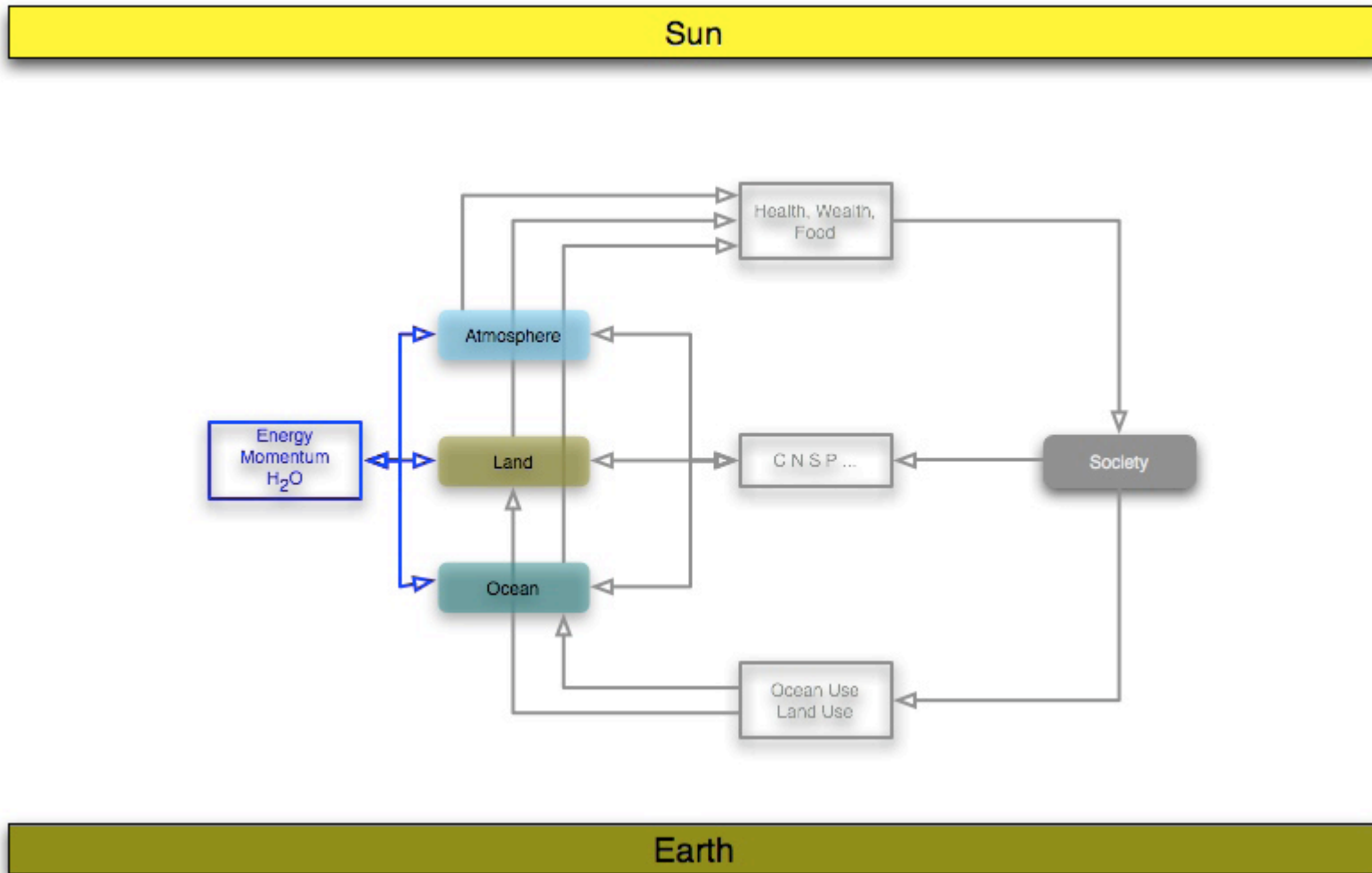

x.x.x = 2.0.0 \diamond „Millennium“ model

cosmos1.0.0.

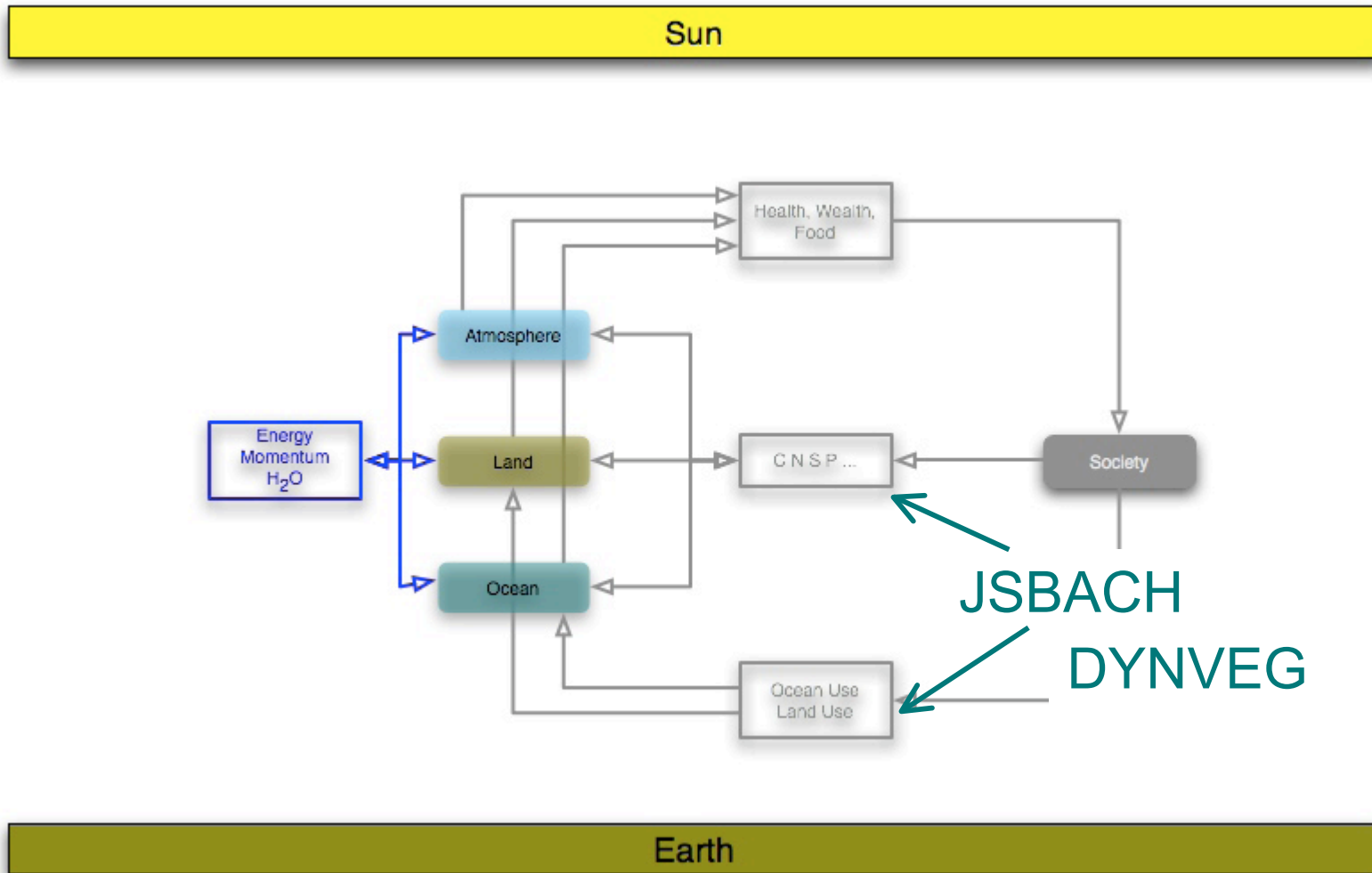

x.x.x ? \diamond model for palaeo applications

cosmos1.0.0.

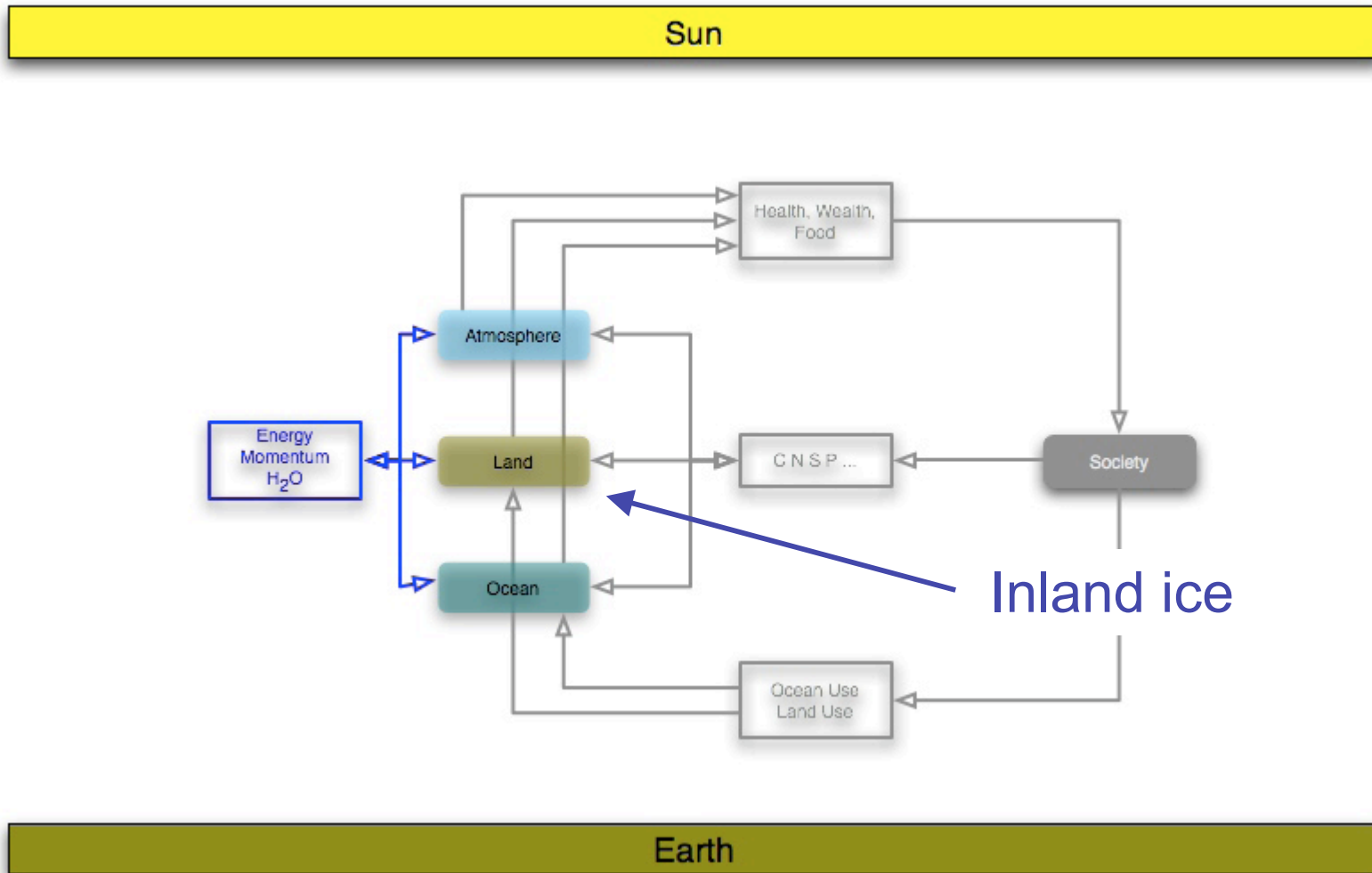

- see Daniela's presentation ...

- Perhaps next time:
„from box model systems
to comprehensive model systems and back“

Inclusion of human dimension interactively – too early?

- Implementation within the new BMBF climate research programme ?!
(COSMOS, an important partner for IPCC AR5)

- COSMOS has now a more efficient structure.
- COSMOS x.x.x are useful tools – the open access idea will pay off.
- COSMOS will be an interesting partner at the European level.



λ Bonus Tracks



Sun Earth System

